



**Precision Plumbing Products**  
*"Specify with Confidence - Install with Pride"*

**LEAD FREE**

**METAL ICE MAKER BOXES**

**INSTALLATION:**

- 1) Position box between studs to desired height.
- 2) Secure box to a backing board or to the front of studs. The front of the box should be flush with the wall material.
- 3) Connect the cold water supply to the valve.
- 4) Install face plate by pushing plate into box until plate is flush against the wall material.

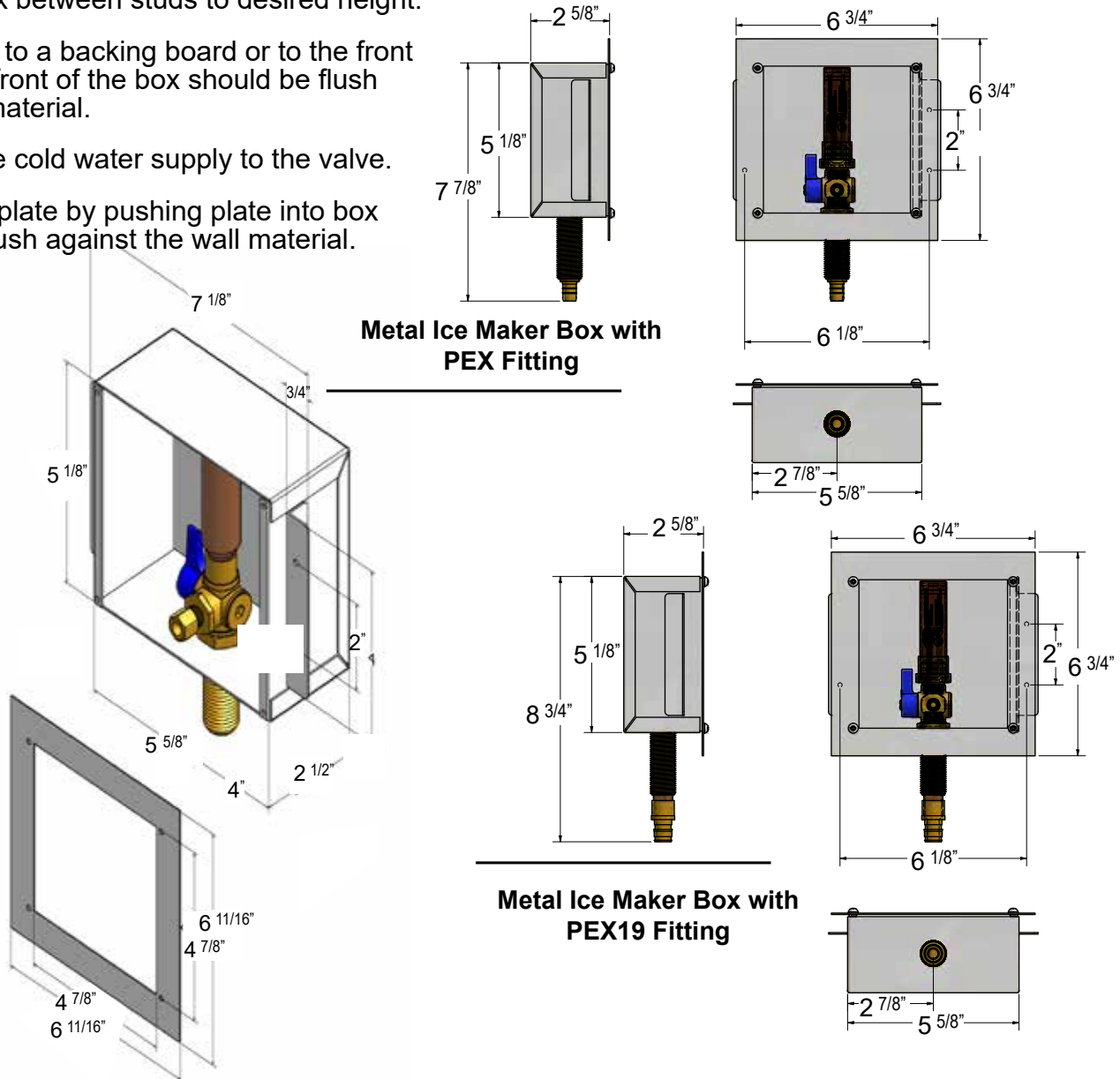

**Precision Plumbing Products**

Division of JL Industries, Inc.

802 SE 199th Avenue  
 Portland, Oregon 97233

T (503) 256-4010  
 F (503) 253-8165

www.pppinc.net



JL Industries, Inc.

NSF/ANSI 61  
 Certified



Rev 03/20